



SOLVANG TECHNOLOGY INC.

www.solvangtech.com

Email : sales@solvangtech.com

10GHZ 50Ω QUICK SMA MALE TO SMA FEMALE

ADAPTER

P/NO.STI01-0171



SPECIFICATION

Frequency	DC-10GHz
VSWR:	1.3:1(Max.)
Impedance:	50ohm
Durability:	500 Cycles
Temperature:	-65~155°C

MATERIAL LIST

Part	Material	Plated
Body	Brass	Gold
Center Pin	Beryllium Copper	Gold
Insulator	Teflon	
Gasket	Silicone Rubber	
C-Ring	Beryllium Copper	Gold

OUTLINE DRAWING

Unit:mm

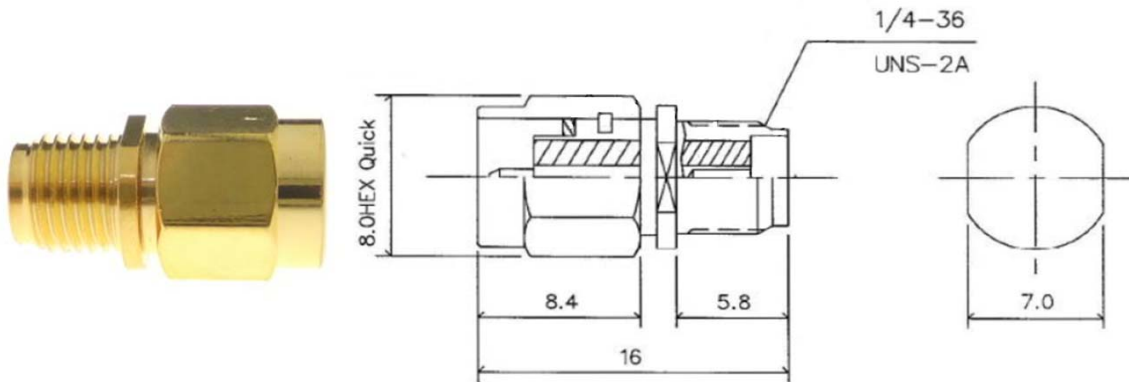

TESTING DATA (100% S-PARAMETER TESTED)

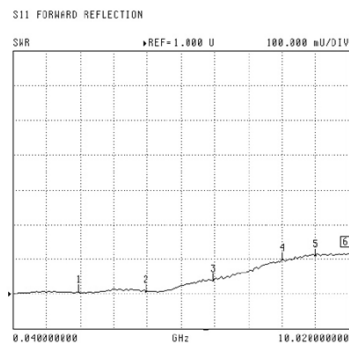
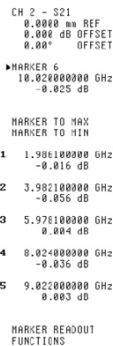
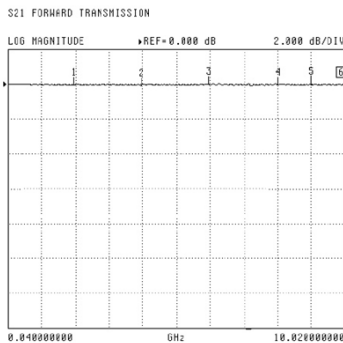

Any more request, please contact sales@solvangtech.com. Thank you ~